

ALL FOOTINGS ADJACENT TO SLOPES TO BE AT LEAST 5' TO DAYLIGHT AS SHOWN BELOW.

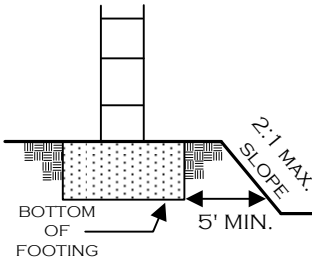

FOOTING REBAR SHALL HAVE A MIN. 6" LONG HOOK AND A MIN. CONCRETE COVER OF 3"

REBAR PLACEMENT ILLUSTRATION

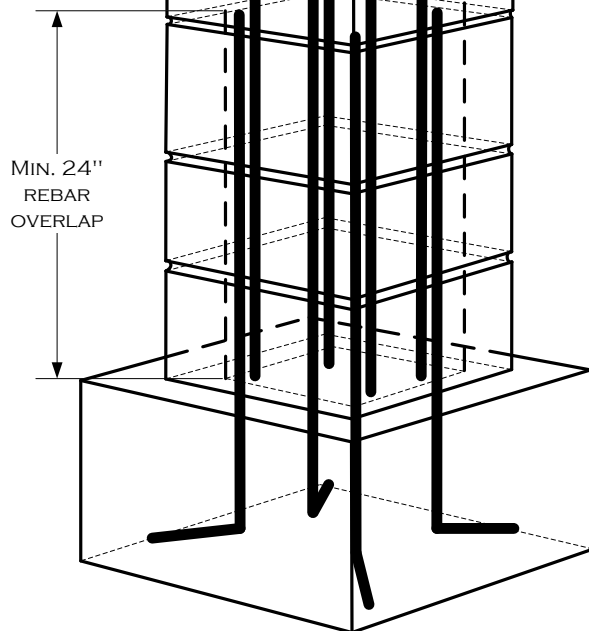

LIMITATIONS:

1. PILASTER SPACING SHALL NOT EXCEED 20 FT. WHEN OTHER INFILL FENCING IS ATTACHED.
2. ONLY OPEN TYPE FENCING (SUCH AS WROUGHT IRON) MAY BE ATTACHED TO PILASTERS. SOLID TYPE FENCING MAY NOT BE ATTACHED TO PILASTER.
3. GATES AND DOORS ATTACHED TO PILASTER ARE LIMITED TO 200# MAX. WEIGHT AND 4 FT. MAX. WIDTH PER PILASTER.
4. THIS PILASTER DESIGN IS INTENDED TO BE USED ONLY AS A FENCING FEATURE AND IS NOT INTENDED TO SUPPORT ANY OTHER LOADS .
5. FENCE HEIGHTS ARE REGULATED – CONSULT ZONING REGULATIONS BEFORE BEGINNING CONSTRUCTION.
6. INSTALLATION OF ELECTRIC CIRCUITS, CONDUITS, OR LIGHTING FIXTURES REQUIRE ELECTRICAL PERMITS AND INSPECTION.
7. FOOTINGS TO BE PLACED IN UNDISTURBED SOIL OR PROPERLY COMPACTED AND ENGINEERED FILL.
8. FOR DESIGN PARAMETERS, SEE FREESTANDING BLOCK WALL STANDARD.

CHECK WITH THE BUILDING & SAFETY DIVISION TO VERIFY IF A BUILDING PERMIT IS REQUIRED.

WHEN A BUILDING PERMIT IS REQUIRED, THE FOLLOWING INSPECTIONS ARE ALSO REQUIRED:

- 1) **FOOTING**; EXCAVATION TRENCH CLEAN WITH STEEL IN PLACE AND SUPPORTED 3" ABOVE AND AWAY FROM THE SURROUNDING THE EARTH/DIRT.
- 2) **REBAR/PRE-GROUT**; VERTICAL REBAR IN PLACE - INSPECTION PRIOR TO PLACING GROUT.
- 3) **FINAL**; AFTER GROUT IS PLACED - PRIOR TO ANY DECORATIVE CAP PLACEMENT.

DISCLAIMER:

ALTERNATE DESIGNS MAY BE POSSIBLE WHEN PROVIDED WITH AN ENGINEERED ANALYSIS. USE OF THIS STANDARD DESIGN IS AT THE USER'S RISK AND CARRIES NO IMPLIED OR INFERRED GUARANTEE AGAINST FAILURE OR DEFECTS.

WESTERN RIVERSIDE COUNTY CODE UNIFORMITY PROGRAM			
		COMMUNITY DEVELOPMENT DEPARTMENT BUILDING & SAFETY DIVISION	
MASONRY PILASTER			
PHONE: (760) 391-4110		100 CIVIC CENTER MALL INDIO, CA 92201	
FAX: (760) 391-4027		03/20/2020	PAGE 1 OF 1