

FOUNDATION PLAN

**TYPICAL**  
4"X8"X15/32"  
Plywood or OSB  
shear panel with  
8d nails at 6" o.c.  
edges, ends, and  
field

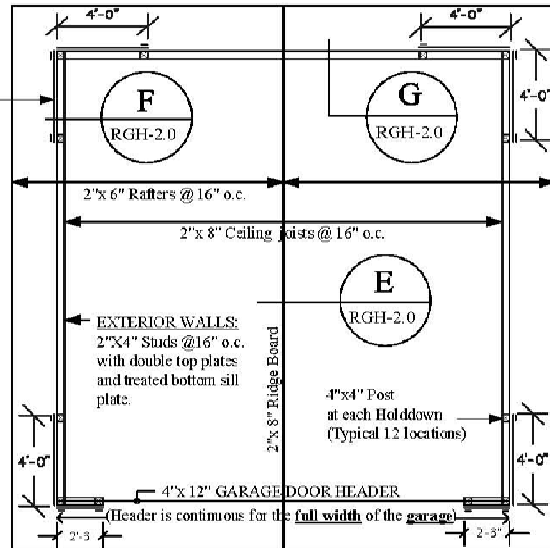

FRAMING PLAN

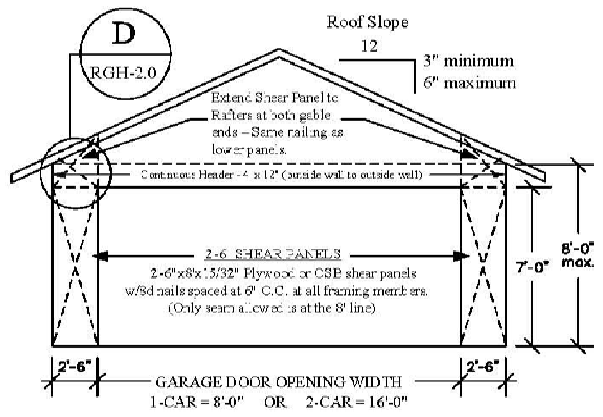

FRONT ELEVATION

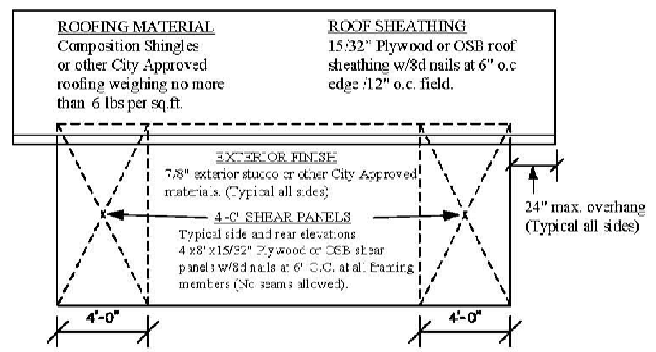

SIDE ELEVATIONS

**NOTES:**

**FOUNDATION REQUIREMENTS**

1. Minimum compressive strength of concrete shall not be less than 3000 psi.  $\Delta$
2. Sill plates shall be pressure treated or foundation grade redwood.
3. Anchor bolts shall be spaced not more than 72" O.C. (except at shear panels where at least 2 bolts are required) and shall be embedded at least 7" into the concrete.
4. Anchor bolts shall be a minimum of 1/2" diameter by 10" in length, with 3"x3"x0.229" plate washers.  $\Delta$
5. There shall be a minimum of two anchor bolts per piece of sill plate with one bolt located not more than 12" or less than 5" from each end.
6. Concrete slab shall not be less than 3-1/2" thick. Reinforcement recommended, but not required, to be 6"x6" x10 gauge welded wire mesh.
7. Footings shall bear on undisturbed soil.
8. Soil at footings and under slab shall be well compacted.

**DOOR & WINDOW LIMITATIONS**

One 36" wide door and one window (up to 48" wide) may be added to any wall as long as it is not located in a shear panel area. Stern wall to be omitted at doors and the headers for such doors and windows shall be 4"x6" Douglas Fir #2 or better.

**ALTERNATE ROOF FRAMING**

Engineered roof trusses may be substituted for the rafters and ceiling joists shown on the plans. Provide calculations from the manufacturer.

**LUMBER**

2"x4" studs shall be "Stud Grade", all other framing lumber shall be Douglas Fir, #2 grade, or better. Ceiling joists are NOT designed for attic storage.  $\Delta$

**ELECTRICAL**  $\Delta$

All electrical outlets (if any) shall be GFCI protected. All electrical (if any) shall conform to the applicable codes and regulations. If electric power is provided to the garage, at least one switch controlled lighting outlet shall be provided inside the garage and one additional at the 3' garage entry door (if one is provided). Check with your Building Inspector and the Utility Department before proceeding with electrical installations.

**DISCLAIMER**

Other garage designs may be possible when provided with an engineered analysis. Use of this conventional standard design is at the user's risk and carries no implied or inferred guarantee against failure or defects.

**CITY OF INDO**  
**BUILDING SAFETY DIVISION**

**STANDARD**  
**DETACH**  
**GARAGE**

100 Civic Center Mall  
Indio, CA 92201  
(760) 541-4211

Sheet  
1 of 2

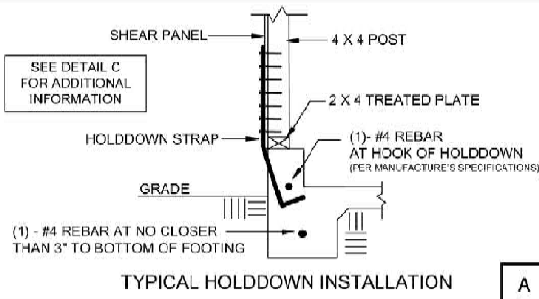

A

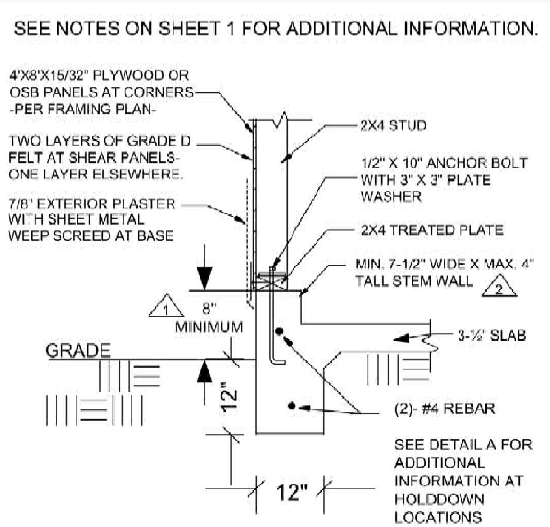

C

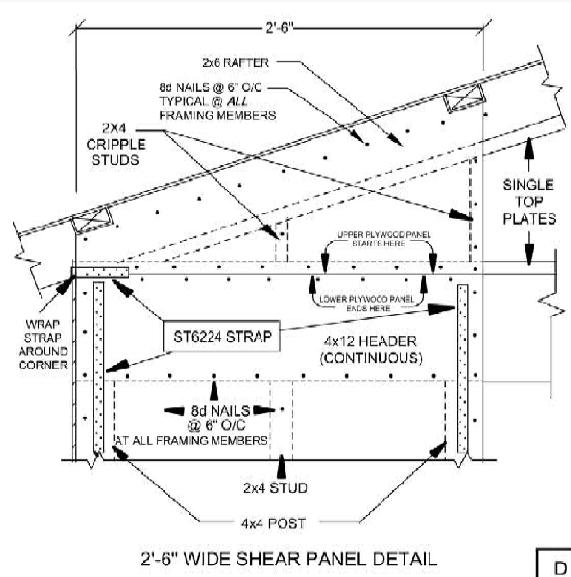

D

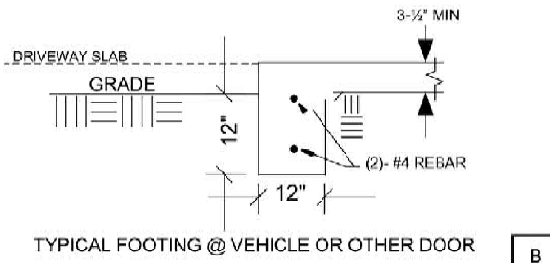

B

NOTE: THIS ROOF FRAMING DESIGN REQUIRES THAT CONTINUOUS 2X8 CEILING JOISTS BE PROVIDED AND ATTACHED TO EACH RAFTER AT THE TOP PLATE LINE PER DETAIL F

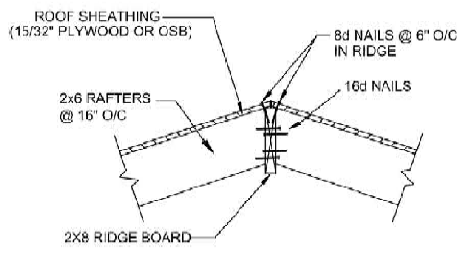

E

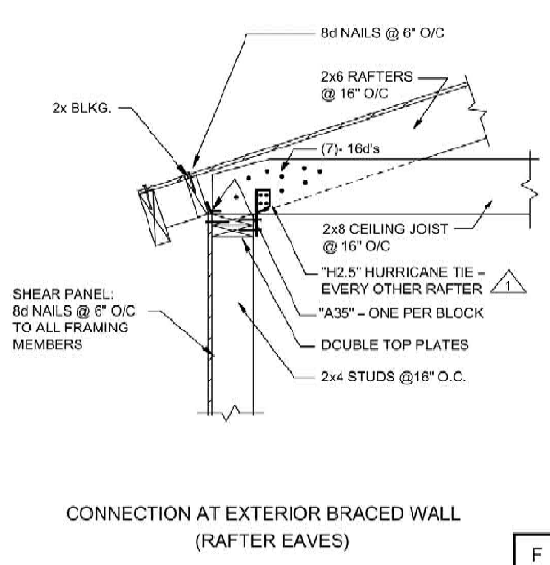

F

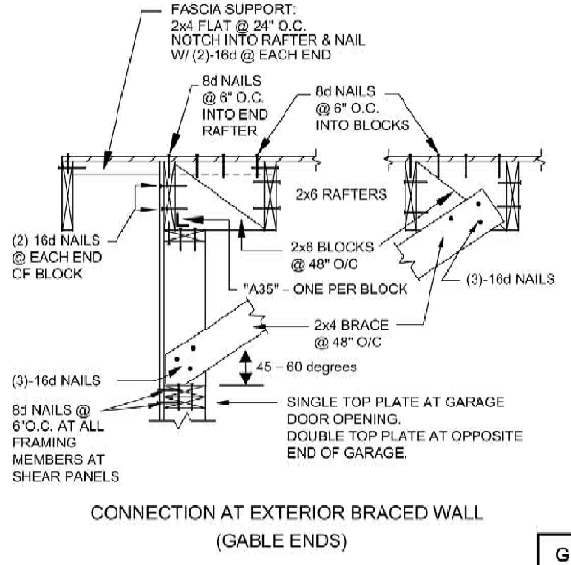

G



CITY OF INDIRIO  
BUILDING SAFETY DIVISION

GARAGE  
DETAILS

Sheet 2 of 2  
100 Civic Center Mall  
Indio, CA 92201  
(760) 541-4211