

IISNS STRAIGHT ARM MOUNTING
N.T.S.

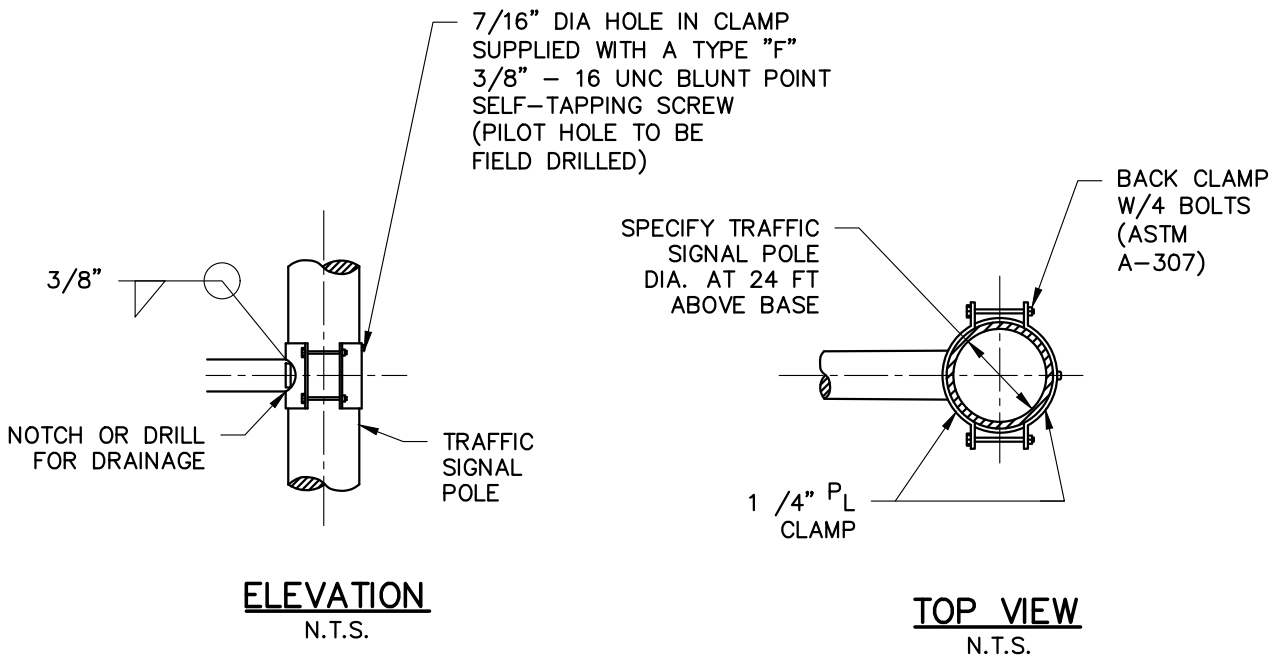

ELEVATION
N.T.S.

TOP VIEW
N.T.S.

L:\Public Works - Engineering Standards\INDIO-212 5/19/2016 12:06 PM



<i>Juan Raya</i>		05/18/16	
JUAN RAYA, P.E. CITY ENGINEER RCE 68510		DATE	
REV.	DRAWN BY:	APP'D:	DATE:



**TRAFFIC SIGNAL POLE
IISNS STRAIGHT ARM
MOUNTING DETAIL**

STANDARD PLAN No.: **212**

MAY 2016