

SECTION "A-A"

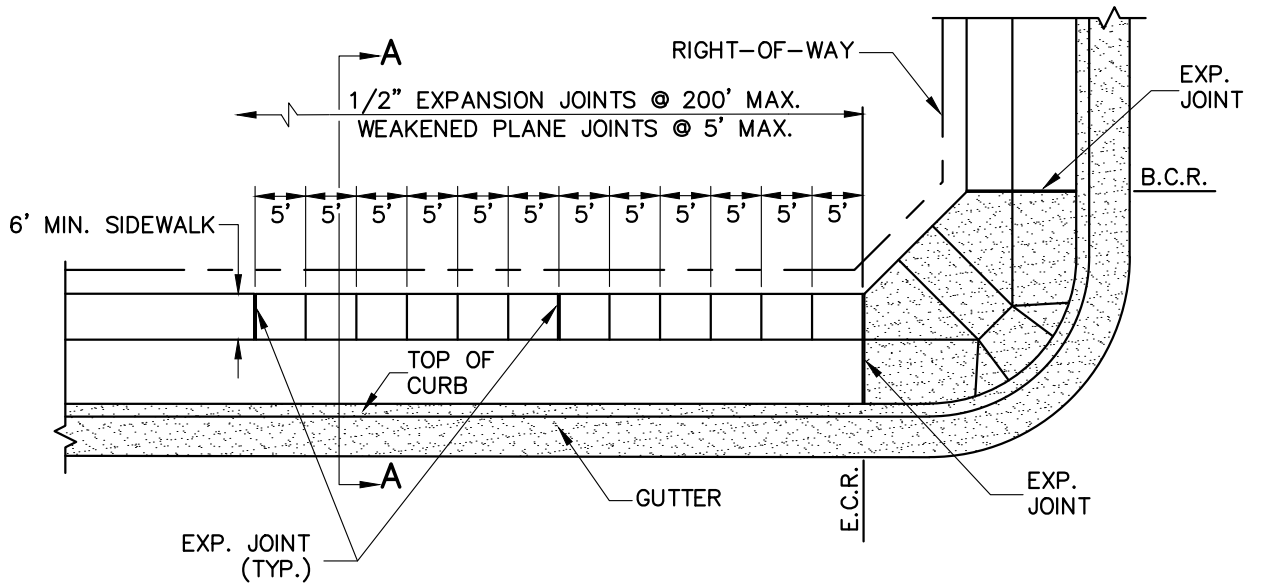

PLAN VIEW

NOTES:

1. THICKNESS OF SIDEWALK SHALL BE 4" EXCEPT IN DRIVEWAY APRONS, WHERE 6" IS REQUIRED FOR RESIDENTIAL DRIVEWAYS, AND 8" IS REQUIRED FOR COMMERCIAL DRIVEWAYS.
2. SIDEWALK SHALL HAVE 1/2" WIDE PRE-MOLDED EXPANSION JOINTS AND 1 1/2" DEEP WEAKENED PLANE JOINTS AT INTERVALS SHOWN HEREON AND PER STANDARD NO. 126. JOINTS SHALL HAVE EDGE WITH 1/4" RADIUS.
3. CONCRETE SHALL BE CLASS 560-C-3250, CURED WITH WHITE PIGMENTED CURING COMPOUND.
4. PARKWAY FROM CURB TO PROPERTY LINE TO BE BROUGHT TO GRADE BY CONTRACTOR BEFORE FINAL APPROVAL.
5. SIDEWALKS SHALL BE FORMED IN SUCH A MANNER AS TO MAINTAIN 48" MINIMUM OF UNOBSTRUCTED PEDESTRIAN WAY AT ALL LOCATIONS, INCLUDING BUT NOT LIMITED TO STREET LIGHTS, POWER POLES, FIRE HYDRANTS, ETC.

L:\Public Works - Engineering Standards\INDIO-133 5/19/2016 11:30 AM



Juan Raya 05/18/16
 JUAN RAYA, P.E.
 CITY ENGINEER
 RCE 68510

REV.	DRAWN BY:	APP'D:	DATE:



**SIDEWALK AT R / W
 AND PARKWAY
 GRADING**

STANDARD PLAN No.:

133

MAY 2016